

OPERATING INSTRUCTIONS

XT543-N / 243 / 343



SPECIFICATIONS

DISPLAY

3 digit, height 0.5".

SET POINTS

Single set point.

DELAY MODES

On delay, Interval, Cyclic on first & Cyclic off first (Configurable by keys).

SUPPLY VOLTAGE

90 to 270 VAC/DC @ 50 or 60Hz.

TIME RANGES

9.99, 99.9, 999 sec, 9:59 min:sec,
99.9, 999 min, 9:59 hr:min, 99.9, 999 hr.
(Configurable by keys).

TIME SETTING

By key pad.

ACCURACY

±0.5% or 50msec.whichever is greater.

START INPUT

Gate / Pulse (Programmable)

RESET INPUT

- 1) Front panel reset (for On delay / Interval only).
- 2) Remote reset.
- 3) On power interruption.

RESET TIME

Less than 100 msec.

COUNTING DIRECTION

Down.

LED INDICATION

Relay status.

OUTPUT

2 C/O.

RELAY RATING

5A@230VAC / 24VDC.

MOUNTING

Panel mounting.
CONFIGURATION LOCK
via rear terminals.

HOUSING

ABS.

TEMPERATURE

Operating: 0 to 50°C. Storage: -5 to 55°C

HUMIDITY

95%RH.

WEIGHT

XT543-N: 160gm, XT243: 285gm, XT343: 300gm

PRODUCT CODE

MODELS	BEZEL SIZE(mm)
XT 543-N	48 x 48
XT 243	72 x 72
XT 343	96 x 96

OVERALL DIMENSIONS (All dimensions in mm)

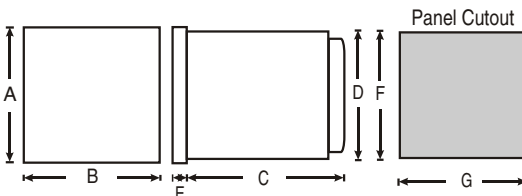

MODELS	DIM	A	B	C	D	E	F	G
XT543-N		48	48	100	45	7	46	46
XT243		72	72	115	68	10	69	69
XT343		96	96	70	90	10	92	92

OPERATING MODES

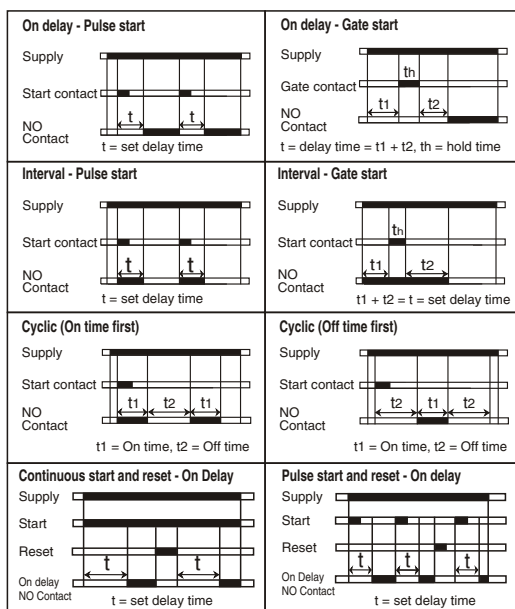

TERMINAL CONNECTIONS

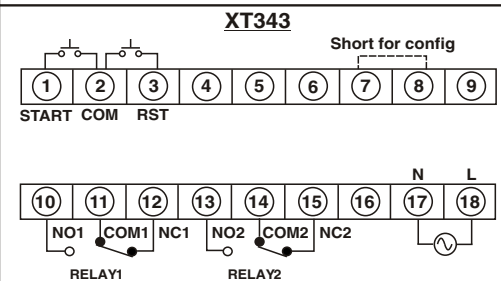
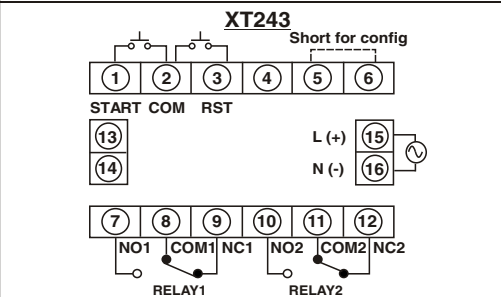
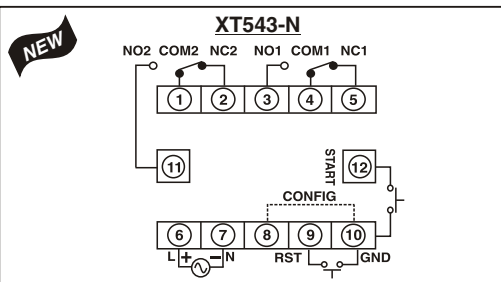

TERMINAL DESCRIPTION	TERMINALS FOR		
	XT543-N	XT243	XT343
L (Live)	6	15	18
N (Neutral)	7	16	17
Short to enter configuration	8 - 10	5 - 6	7 - 8
COM of relay 1	4	8	11
NO of relay 1	3	7	10
NC of relay 1	5	9	12
COM of relay 2	1	11	14
NO of relay 2	11	10	13
NC of relay 2	2	12	15
START input	12 - 10	1	1
RESET input	9 - 10	3	3
COM (Gnd)	10	2	2

PROGRAMMING SCHEME		
CONFIGURATION SCHEME : 1) At power OFF, short terminals for configuration*. 2) Turn power ON. 3) Program configuration setting as per instructions below.		
NOTE : LSD dp blinks during programming. *For XT543-N short terminals 8 & 10 for XT243 short terminals 5 & 6 for XT343 short terminals 7 & 8 to enter into the configuration mode.		
1. TO SELECT RANGE Default Setting : 9.99sec		
KEY PRESS	DISPLAY	DESCRIPTION
RANGE		9.99sec
PRESS 0 + A		99.9sec
PRESS 0 + A		999sec
PRESS 0 + A		9:59 min:sec (MSD dp blinks when the timing is in progress.)
PRESS 0 + A		99.9min
PRESS 0 + A		999min
PRESS 0 + A		9:59 hr:min (MSD dp blinks when the timing is in progress.)
PRESS 0 + A		99.9hr
PRESS 0 + A		999hr
2. PRESS A KEY TO SELECT DELAY MODE Default Setting : On Delay		
KEY PRESS	DISPLAY	DESCRIPTION
DELAY MODE		ON DELAY
PRESS 0 + A		INTERVAL DELAY
PRESS 0 + A		CYCLIC (ON FIRST)
PRESS 0 + A		CYCLIC (OFF FIRST)
3. PRESS A KEY TO ENABLE / DISABLE FRONT PANEL RESET OPTION Default Setting : Enabled. Note: Valid only for On delay / Interval mode.		
KEY PRESS	DISPLAY	DESCRIPTION
FRONT PANEL RESET		ENABLED (YES)
PRESS 0 + A		DISABLED (NO)

4. PRESS **A** KEY TO SELECT START INPUT
Default Setting : Pulse Start.

KEY PRESS	DISPLAY	DESCRIPTION
START INPUT	4 0	GATE START
PRESS 0 + A	4 1	PULSE START

Pulse start: In Pulse start mode, the timing starts on momentary closure of the Start switch.

Gate start: In Gate start mode, when the Start switch is closed, the timing stops and proceeds only after the start switch is released.

5. PRESS **A** KEY TO RESET ALL PARAMETERS TO DEFAULT VALUE

Note: Reset all function is used only to set all parameter values back to default.

KEY PRESS	DISPLAY	DESCRIPTION
RESET ALL	5 0	NO ACTION
PRESS 0 + A	5 1	NO ACTION
PRESS 0 + A	5 2	NO ACTION
PRESS 0 + A	5 3	NO ACTION
PRESS 0 + A	5 4	NO ACTION
PRESS 0 + A	5 5	NO ACTION
PRESS A	1 0	RESET ALL

AFTER CONFIGURATION SETTING :

- 1) Turn power OFF.
- 2) Remove link between the terminals.
- 3) Turn power ON.

TO PROGRAM SET TIME :

FOR ON DELAY / INTERVAL MODE :

Press **0** + **A** / **0** to program set time.

For Cyclic mode :

ON time - Press **0** + **A** / **0** to program on time

OFF time - To enter programming of off time

press **A** + **0** for 3sec. When in Off time programming, the LSD dp blinks. Then press **0** + **A** / **0** to set off time.

To Exit programming press **A** + **0** for 3sec or auto program out after 60sec if no key is pressed.

TO RESET :

For On delay / Interval mode : Press **A** + **0** for 0.6sec to reset.

For Cyclic mode : Front reset not valid.

Reset only through pulse given From rear terminals.

LOAD CONNECTIONS

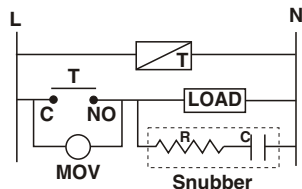

1) Snubber Part No.: APRC - 01.

2) MOV Part No.: AP-MOV - 03.

Note: For inductive loads, use of snubber and MOV, as shown above, is recommended.

USER GUIDE

Typical applications of Pulse start & Gate start input:

1. ON Delay with Pulse start input:

- i. Terminal connections shall be as per fig. 1
- ii. Timing starts on momentary closure of Start switch.
- iii. If Start switch is kept closed continuously, the timing will start at every power ON or reset.

XT543-N in ON Delay mode and Pulse start input: Fig.1 Terminal Connections

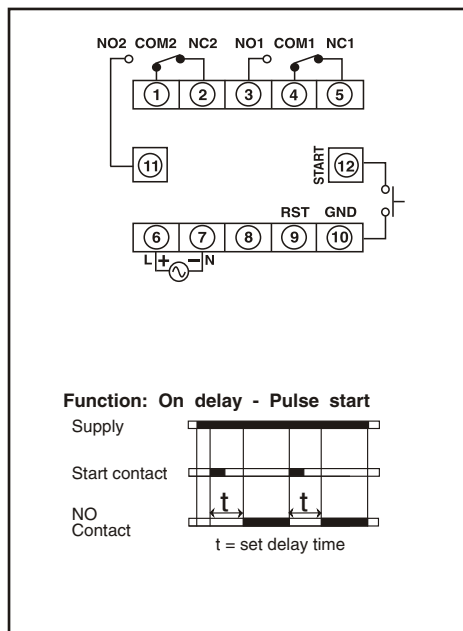

2. ON Delay with Gate start Input:

- i. Terminal connections shall be as per fig. 2.
- ii. Timing starts at power ON.
- iii. When the start switch is closed, the timing is held and it proceeds only after the start switch is released.

XT543-N in ON Delay mode and Gate start input: Fig.2 Terminal Connections

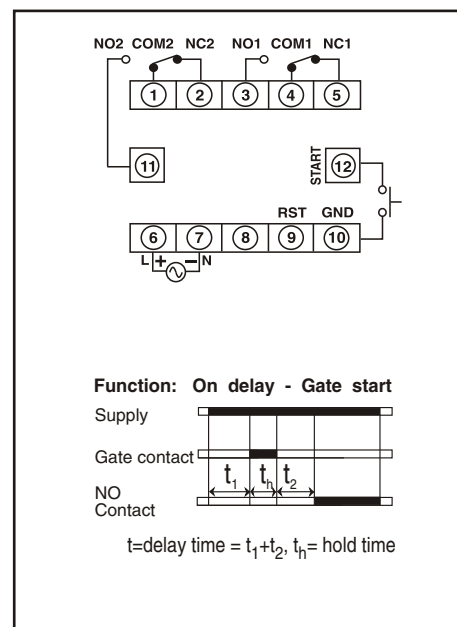

(Specifications subject to change as development is a continuous process).

SELECTRON Process Controls Pvt.Ltd.,
E-121, Ansa Ind. Estate, Saki Vihar Rd, Andheri (E)
Mumbai - 400 072. India,
Website: www.selecindia.com. E- mail: sales@selecindia.com.